

## INSTALLATION GUIDE - Thru Bore Slip Rings

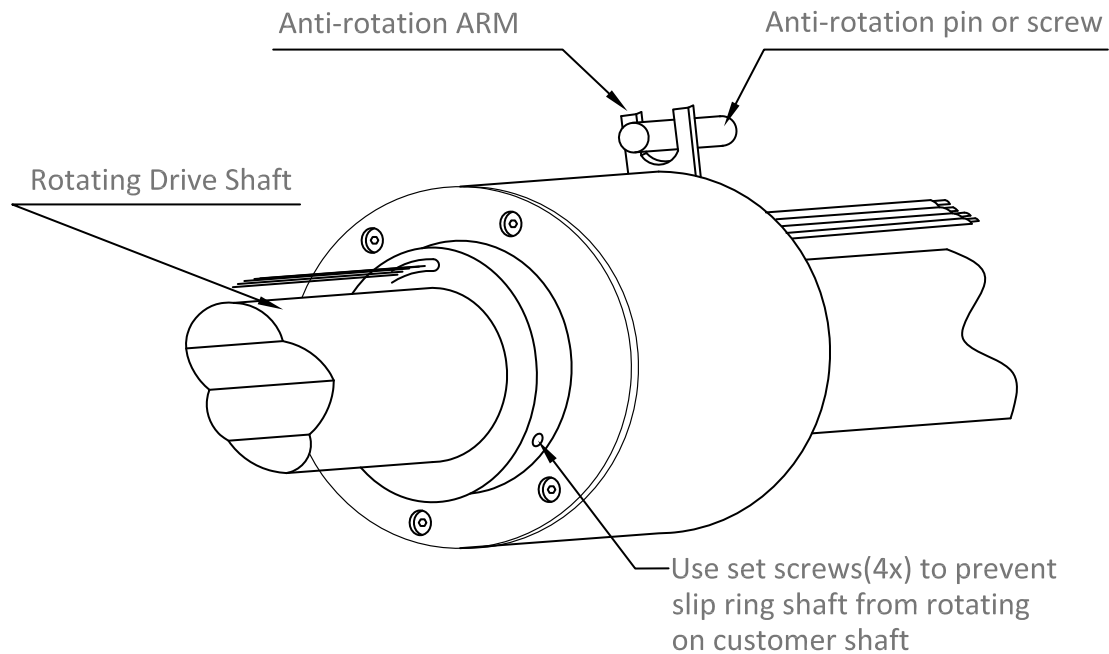

1. Position capsule slip ring assembly onto shaft and fix slip ring rotor shaft with 2x set screws or alternatively cement shaft with suitable adhesive.
2. Align anti-rotation pin or screw with slot in anti-rotation arm.
3. Fully engage pin or screw into slot.
4. Ensure that terminations are correctly wired and retained as necessary.
5. Secure the leads so that they do not contact any surface of the equipment as it rotates. While routing the wires, do not allow the leads to apply any side loading to the slip ring.