

MP8-H Series Overview

Description

Cosmau MP8-H series multiple passage rotary unions with 8 channel for media transfer, design for oil, water and coolant in rotating system.

- Transmit hydraulic oil, water and coolant when 360°unrestricted rotation
- Combined with electrical slip ring,transfer power,control signal, data
- Through hole or flange structure optional
- Available all kinds of custom solutions



Specifications

Item	
Pneumatic Channel	8
Pressure	Max. 350bar
Connection Szie	1/8" 1/4", 3/8", 1/2", 3/4", 1"
Connection Type	BSPB
Operating Temperature	-18° C to 150° C
Suitable Media	Oil / Water / Coolant
Speed	Max. 200 RPM
Material	AL alloy housing, Carbon Steel / Stainless Steel Shaft

Note: All values listed under Technical Specifications are dependent on a combination of all application parameters. Please note service life is dependent upon both rotational speed and duty cycle.

Options

- Mounting Flange / Through Hole
- Connection Size
- Connection Type
- Material
- Pressure
- Media
- Optional Speed
- Combine with electrical slip ring

INTRODUCE

MP8-H

11

MP8-H Series Dimensions

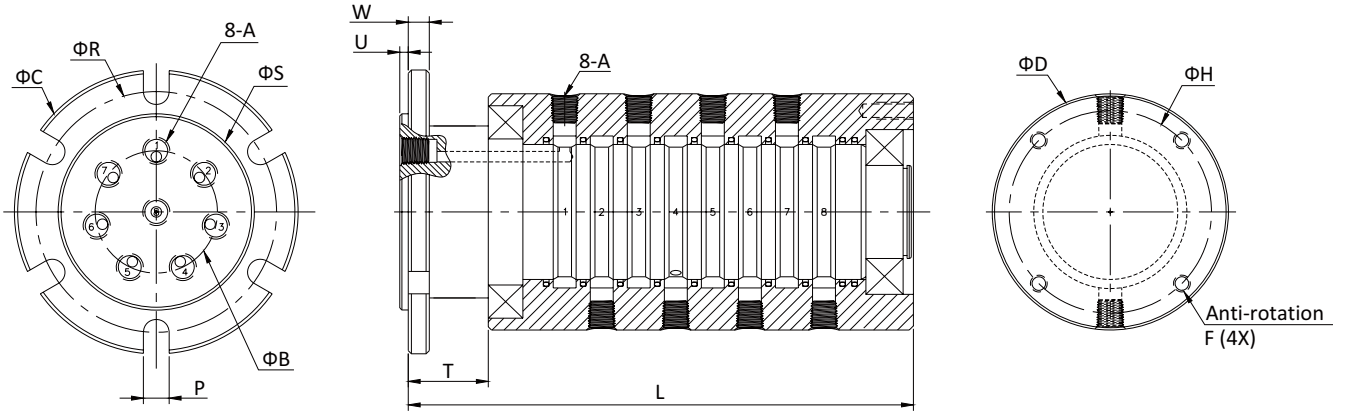

Part#	A(BSPP/NPT)	ΦB	ΦC	ΦD	ΦR	ΦS	U	W	T	P	F	ΦH	L
MP-801-H	1/8"	53	94.5	74.5	84	72.5	3	6	24	6.5	M6	64	211.4
MP-802-H	1/4"	58	104	79	93.5	81	3	6	24	6.5	M6	68.5	229.4
MP-803-H	3/8"	67	114.5	98.5	104	93	3	6	24	6.5	M6	88	267.6
MP-804-H	1/2"	81	139.5	109	126.5	112.5	3	8	32	9	M8	96	320.6
MP-805-H	3/4"	100	164.5	133.5	151.5	121	4	9	32	9	M8	120.5	361.6

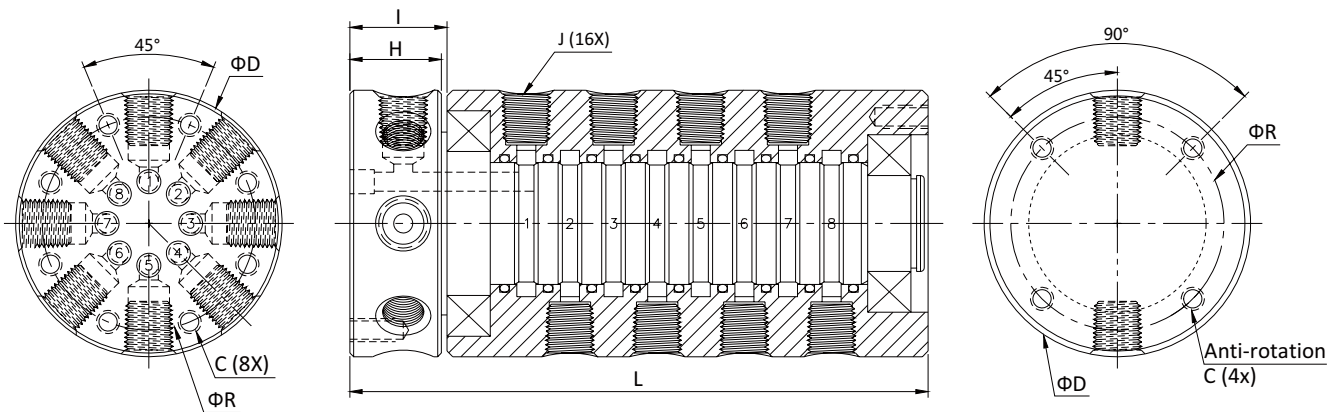

Part#	J(BSPP/NPT)	ΦR	C	ΦD	H	I	L
AP-801-H	1/8"	64	M6	74.5	19.5	20	214.8
AP-802-H	1/4"	64	M6	74.5	22.5	23	228.4
AP-803-H	3/8"	79	M6	89.5	28.5	29	278.4
AP-804-H	1/2"	97	M8	109.5	33.5	34	320.5
AP-805-H	3/4"	117	M8	129.5	42.5	43	368.4
AP-806-H	1"	135	M10	149.5	56.5	57	443.5